

**CAMBRIDGE INTERNATIONAL EXAMINATIONS**  
GCE Ordinary Level

[www.PapaCambridge.com](http://www.PapaCambridge.com)

## **MARK SCHEME for the May/June 2013 series**

### **7010 COMPUTER STUDIES**

**7010/12**

Paper 1, maximum raw mark 100

This mark scheme is published as an aid to teachers and candidates, to indicate the requirements of the examination. It shows the basis on which Examiners were instructed to award marks. It does not indicate the details of the discussions that took place at an Examiners' meeting before marking began, which would have considered the acceptability of alternative answers.

Mark schemes should be read in conjunction with the question paper and the Principal Examiner Report for Teachers.

Cambridge will not enter into discussions about these mark schemes.

Cambridge is publishing the mark schemes for the May/June 2013 series for most IGCSE, GCE Advanced Level and Advanced Subsidiary Level components and some Ordinary Level components.

Page 2	Mark Scheme	Syllabus	
	GCE O LEVEL – May/June 2013	7010	

- 1 (a) Any **two** items from the list:
- purpose of the system/program/software/package*
  - program listing/coding
  - programming language used
  - flowcharts/algorithms/pseudocode
  - screen (input) formats/layouts*
  - hardware requirements
  - software requirements
  - (minimum) memory requirements
  - known bugs
  - list of variables (and their meaning)/data dictionary
  - file structures
  - sample runs*
  - output formats/layouts*
  - validation rules
  - meaning of error messages*
  - installation guide*

[2]

- (b) Any **two** items from the list:
- purpose of the system/program/software/package*
  - how to log in/log out
  - how to load/run software
  - how to save/load files
  - how to do a search
  - how to sort data
  - how to print (out documents/files)
  - how to delete/add/amend records
  - screen (input) formats/layouts*
  - output formats/layouts*
  - hardware requirements
  - software requirements
  - sample runs*
  - meaning of error messages*
  - troubleshooting/help/FAQs
  - tutorials
  - installation guide*

[2]

<b>Page 3</b>	<b>Mark Scheme</b>	<b>Syllabus</b>
	<b>GCE O LEVEL – May/June 2013</b>	<b>7010</b>

2 1 mark for each correctly identified use of data storage medium (column):

	CD-ROM	DVD-RAM	fixed hard disk	memory stick
storage medium where data can only be read and not altered	✓			
portable medium which allows transfer of data between computers				✓
memory where operating systems and applications software are usually stored			✓	
medium which allows recording and playback to occur at the same time		✓		

3 (a) 1 mark for type of memory used and 1 mark for data transfer method.

<b>chosen device</b>	<b>type of internal memory</b>	<b>method of transferring data</b>
<b>MP3 player</b>	<ul style="list-style-type: none"> <li>– (NAND) flash memory</li> <li>– solid state memory</li> <li>– type of EEPROM</li> <li>– non-volatile memory</li> <li>– SD card</li> </ul>	<ul style="list-style-type: none"> <li>– using USB (port/cable) in computer</li> <li>– blue tooth/WiFi connection</li> <li>– slot card into computer card reader</li> </ul>
<b>digital camera</b>	<ul style="list-style-type: none"> <li>– (NAND) flash memory</li> <li>– solid state memory</li> <li>– type of EEPROM</li> <li>– non-volatile memory</li> <li>– SD card or XD card</li> </ul>	<ul style="list-style-type: none"> <li>– using USB (port/cable) in computer</li> <li>– blue tooth/WiFi connection</li> <li>– slot card into computer card reader</li> </ul>
<b>mobile phone</b>	<ul style="list-style-type: none"> <li>– (NAND) flash memory</li> <li>– solid state memory</li> <li>– type of EEPROM</li> <li>– non-volatile memory</li> <li>– SD card</li> </ul>	<ul style="list-style-type: none"> <li>– using USB (port/cable) in computer</li> <li>– blue tooth/WiFi connection</li> <li>– slot card into computer card reader</li> </ul>

[2]

(b) (i) Any **one** disadvantage from:

- memory size in mobile phone is usually much smaller
- many MP3 features (e.g. shuffle) not available on the mobile phone
- track/song can be interrupted by an incoming call on a mobile phone

[1]

(ii) Any **one** disadvantage from:

- poorer quality of image due to phone's inferior camera lens/fewer pixels /lower resolution
- stores fewer pictures
- fewer photographic options

[1]

Page 5	Mark Scheme	Syllabus
	GCE O LEVEL – May/June 2013	7010

4 (a) 1 mark for each correct health and safety risk identified:

potential risk	health issue	safety issue
<i>repetitive strain injury (RSI) caused by excessive clicking of a mouse or typing</i>	✓	
<i>trailing wires connected to a computer system</i>		✓
<i>ozone gas and toner particles produced during laser printer operation</i>	✓	
<i>headaches and eye strain caused by glare from a computer monitor/screen</i>	✓	
<i>electrocution risk caused by spilling liquids on a computer system</i>		✓

[5]

(b) Any **three** from:

- loss of work/unemployment
- de-skilling of workers
- need for workers to re-train
- can work from home/remote working
- use of video conferencing rather than face to face meetings
- quieter environment in the office
- more use of “out sourcing” of work (workers become project managers)
- use of computer for non-work related activities (*accept an example of this*)

[3]

5

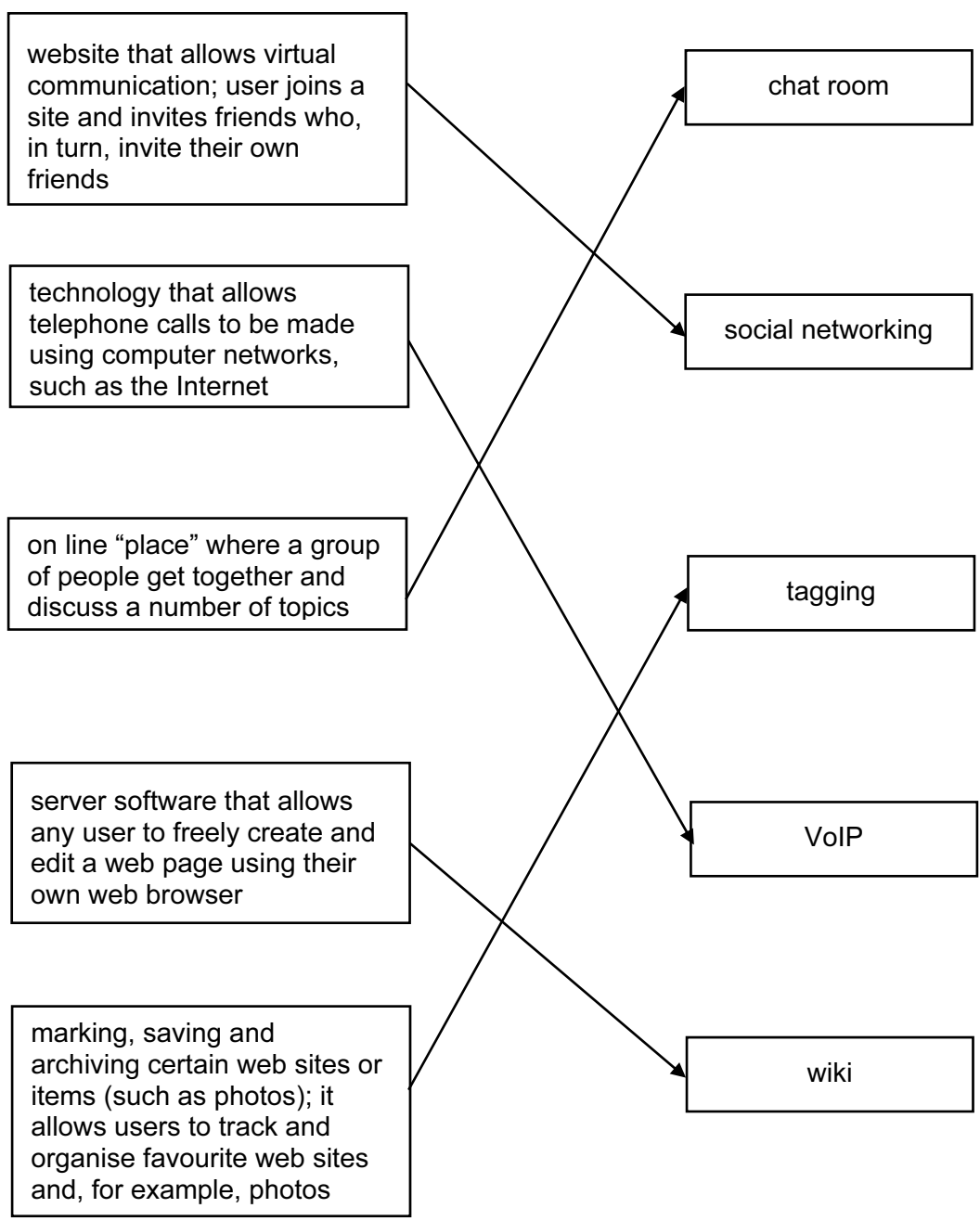

[4]

Page 7	Mark Scheme	Syllabus	
	GCE O LEVEL – May/June 2013	7010	

- 6 (a) Any **one** from:
- not possible to save data on a CD-ROM
  - CD-ROMs are read only
  - data cannot be altered on a CD-ROM
- (b) Any **one** from:
- WiFi only connects devices together in the home/connects to router
  - still need Internet external connection via telephone network/wires
- [1]
- (c) Any **one** from:
- satellites send signals **TO** (the GPS system in) the car (sat nav)
  - GPS device and NOT the satellite works out the cars' location
- [1]
- (d) Any **one** from:
- Messages left in the inbox/stored on server
  - and then opens it/reads message at their leisure
- [1]
- (e) Any **one** from:
- not true since time zones/differences prevent this
  - meetings can be held **at short notice** (which is very different)
- [1]

Page 8	Mark Scheme	Syllabus
	GCE O LEVEL – May/June 2013	7010

- 7 (a) Any **four** points from:
- (light) sensor sends data signals about spinning CD to microprocessor
  - the signals/data are converted from analogue to digital (by an ADC)
  - microprocessor uses data and “counts” number of CD revolutions per second/calculates speed of revolution
  - this calculated/received value is compared to the value stored in memory
  - if the number of revolutions/speed is out of acceptable range microprocessor sends a signal ...
  - ... and the CD speed is increased/decreased accordingly
  - an error message is also sent if the speed is out of range
- [4]
- (b) Any **two** points from:
- sensors indicate sudden jolt/movement
  - data from CD stored in a temporary memory/buffer
  - there is a (2 to 4 second) delay in “real time” playback
  - playback is suspended until device is stable again
- [2]
- (c) Any **one** from:
- no moving parts e.g. no spinning CDs, solid state
  - no “physical” media
- [1]



8 (a)

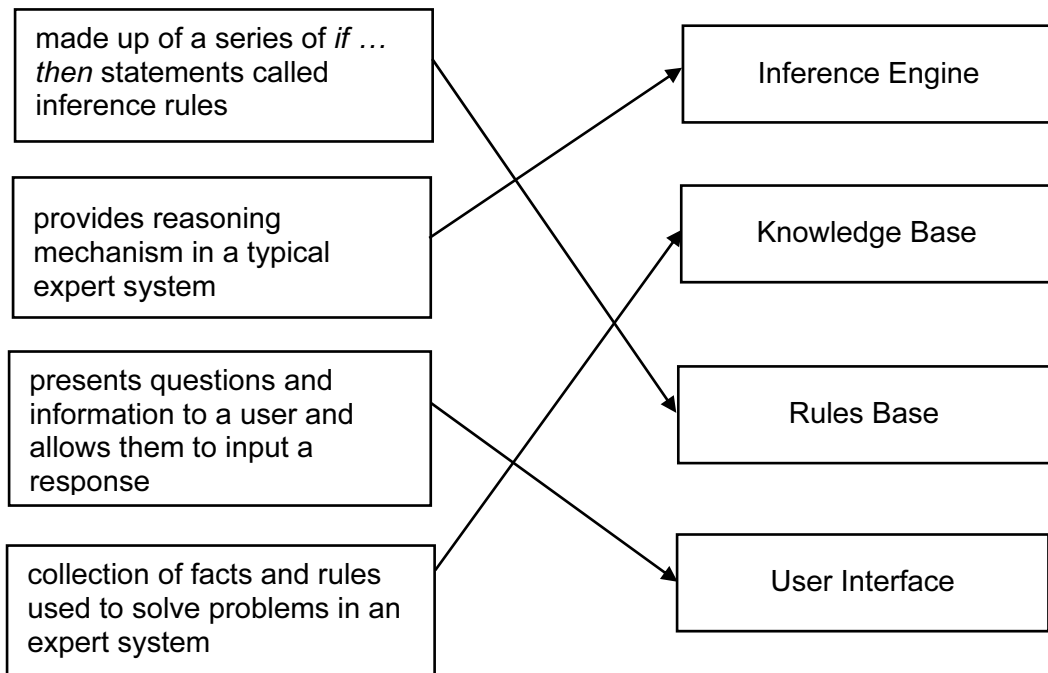

[3]

(b) Any **three** from:

- lack human common sense
- cannot make creative responses in unusual/new circumstances
- can't always explain clearly their logic and reasoning
- lack a degree of flexibility
- not able to recognize when no answer is actually available
- do not learn unless the knowledge base/expert system is updated
- only give percentage probability that answer could be correct

[3]

Page 10	Mark Scheme	Syllabus
	GCE O LEVEL – May/June 2013	7010

- 9 (a) Any **two** from:
- can put the film anywhere (e.g. stick on a curved wall)
  - can fit to awkward shapes where rigid screen would be impossible
  - can be any size required
  - self-contained unit
  - use less energy
  - less physical space required
- [2]
- (b) Any **two** from:
- advertising (e.g. in railway stations, airports, etc.)
  - books/magazines/newspapers made out of the thin film
  - art (i.e. moving pictures, light shows, etc.)
  - any screen application e.g. TV, mobile phone etc.
- [2]
- 10 (a) Any **one** from:
- allows digital systems to use analogue phone networks
  - convert analogue – digital – analogue
  - digital signal converted from one form to another (for transmission)
- [1]
- (b) Any **two** from:
- blocks unauthorized external users gaining access to the intranet
  - blocks programs/software gaining access to Internet from intranet
  - filters out certain websites to users of intranet when accessing the Internet
  - aids/helps to prevent viruses
  - packet inspection/traffic flow monitoring
- [2]
- (c) Any **two** from:
- hacking
  - viruses/malware
  - security issues (pharming, phishing, spyware, etc.)
  - access to undesirable web sites
  - abuse of computer time by work force
- [2]

Page 11	Mark Scheme	Syllabus	
	GCE O LEVEL – May/June 2013	7010	

11 (a) (i) 5

(ii) 8

(b) M3 and M8 only

[1]

(c) (Cars per day > 50 000) OR (Toll charge per km (\$) > 0.50)

<----- (1 mark) -----> <----- (1 mark) ----->

Or

(Toll charge per km (\$) > 0.50) OR (Cars per day > 50 000)

<----- (1 mark) -----> <----- (1 mark) ----->

[2]

12 (a) a

A	B	C	D	E	K	X
3	5	1	4	8	0	0
5	3				3	1
		4	1		1	1
			8	1	1	1
						0
	4	3			3	1
		8	3		3	1
						0
	8	4			4	1
						0
8	5				5	1
						0

< - - - - 1 mark - - - - > < 1 mark > < - - - - 1 mark - - - - > < 1 mark > < 1 mark >

[5]

(b) 8, 5, 4, 3, 1

[1]

(c) SORT/ORDER (descending) routine

[1]

(d) – would continue looping round even when sorting complete  
 – loop would never end/infinite loop

[1]

Page 13	Mark Scheme	Syllabus
	GCE O LEVEL – May/June 2013	7010

- 13 (a) (i) name: – character/type check  
– presence check
- address: – character/type check  
– presence check  
– use lookup file/database
- type of card: – character/type check  
– presence check  
– consistency check  
– format check
- card number: – length check  
– format check  
– check digit  
– range check  
– character/type check  
– presence check

(need different validation check for each item) [4]

- (ii) – type of credit/debit card [2]  
– limited number of possible options

- (b) date of birth – drop down boxes of day, month and year  
– use of input boxes:
- 
- calendar object

- male or female – radio buttons  
– tick/check boxes  
– drop down/combo box

- accept/decline company conditions – tick/check boxes  
– radio buttons  
– drop down/combo box [3]

Page 14	Mark Scheme	Syllabus
	GCE O LEVEL – May/June 2013	7010

14 (a) sequence of colours is: blue  
green  
white  
time delay is: 7 seconds [2]

(b) 

1	0	1	0	0	1
---	---	---	---	---	---

1	0	1
---	---	---

  
<----- 1 mark ----->     <-- 1 mark --> [2]

(c) – sequence always starts from left to right  
– so sequence would still be red, blue then green [2]

15 (a)

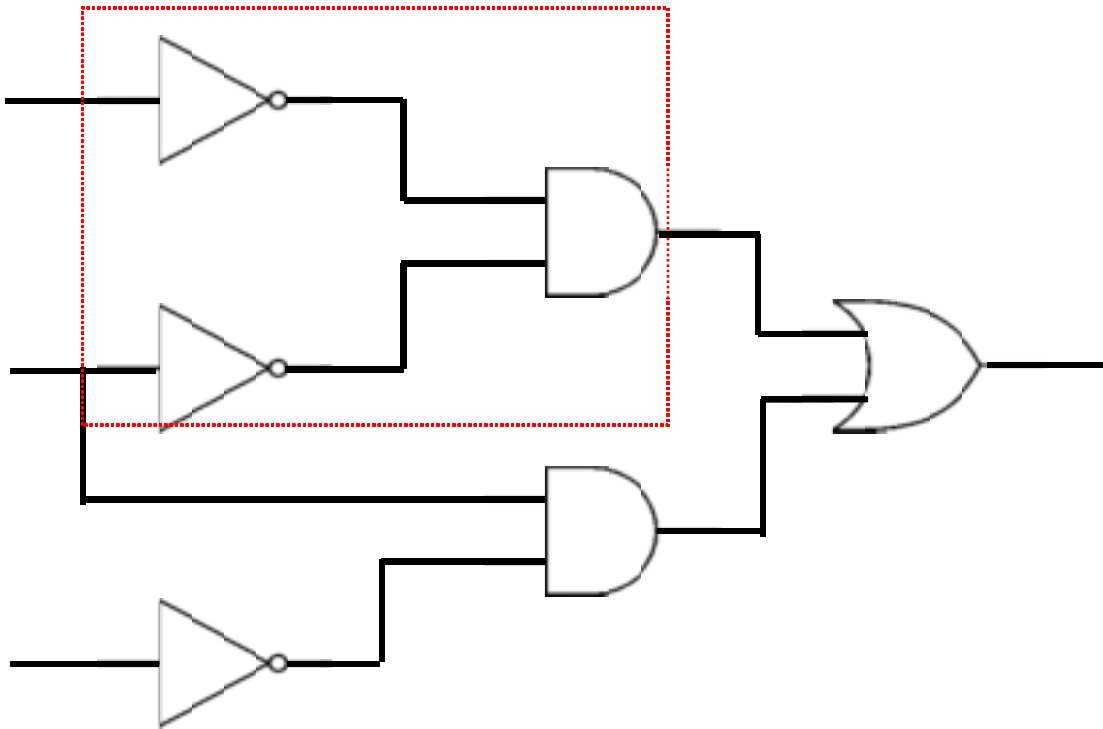

1 mark per correct logic gate

(Accept other notation for logic gates)

[6]

(b)

B	S	P	X
0	0	0	1
0	0	1	1
0	1	0	1
0	1	1	0
1	0	0	0
1	0	1	0
1	1	0	1
1	1	1	0

}  
}  
}  
}

[4]

16

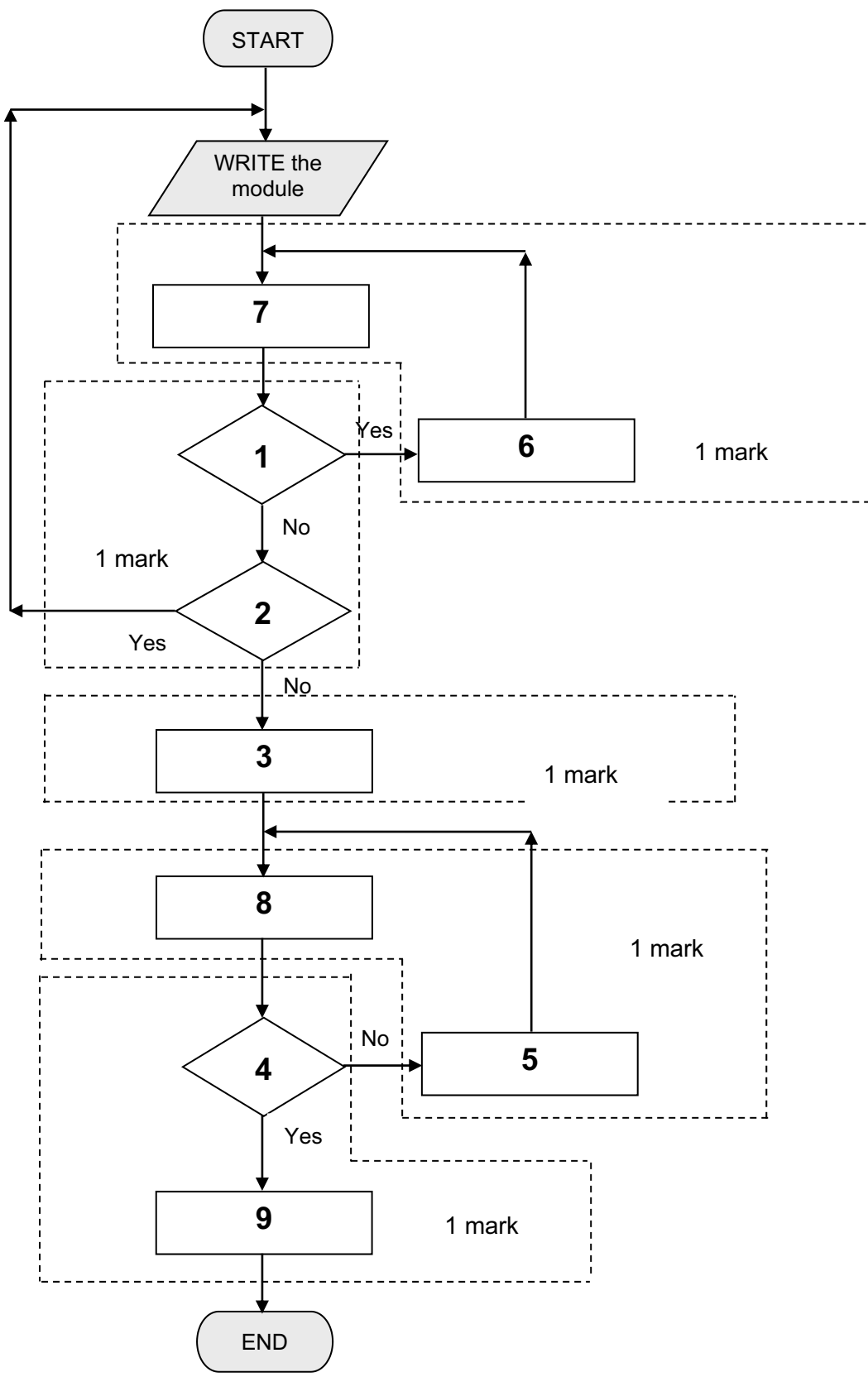

[5]



Page 17	Mark Scheme	Syllabus	
	GCE O LEVEL – May/June 2013	7010	

**17 marking points:**

- initialisation of all the variables 1 mark
- corrects loop (1 to 50 000) 1 mark
- input number (INSIDE a loop) 1 mark
- how to identify the first 3 digits in the input number 1 mark
- test which of the 4 networks number comes from 1 mark
- increment appropriate network total (INSIDE a loop) 1 mark
- addition of some form of error checking 1 mark
- output totals (OUTSIDE the loop) 1 mark

**sample coding:**

```
Y = 0: N = 0: K = 0: S = 0 1 mark
for count = 1 to 50 000 1 mark
  input number 1 mark
  X = number/100 000 000 1 mark
  if X > 0.7 then S = S + 1 }
    else if X > 0.6 then K = K + 1 } 2
      else if X > 0.5 then N = N + 1 } marks
        else if X > 0.4 then Y = Y + 1 }
          else print "error in number" 1 mark
next count
print Y, N, K, S 1 mark
```

[6]